

INITIAL RECEIPT

United States Department of the Interior
Bureau of Land Management
 DIV OF LANDS, MINRLS & ENERGY
 ONE N CENTRAL AVE
 PHOENIX, AZ 85004 -4427
 Phone: 602-417-9200

Receipt

No: 4840846

Transaction #: 4969008	
Date of Transaction: 11/23/2020	
CUSTOMER:	
CORIZONA LLC 242 LINDEN ST FORT COLLINS, CO 80524-2424 US	

LINE #	QTY	DESCRIPTION	REMARKS	UNIT PRICE	TOTAL
1	7.00	LOCATABLE MINERALS / MINING CLAIMS-NEW, UNADJUD, ONE OR MORE AUTH NOS / NEW MINING CLAIM PROCESSING FEE CASES: AMC461850/\$20.00, AMC461851/\$20.00, AMC461852/\$20.00, AMC461853/\$20.00, AMC461854/\$20.00, AMC461855/\$20.00, AMC461856/\$20.00		- n/a -	140.00
2	7.00	LOCATABLE MINERALS / MINING CLAIMS-NEW, UNADJUD, ONE OR MORE AUTH NOS / NEW MINING CLAIMS LOCATION FEE CASES: AMC461850/\$40.00, AMC461851/\$40.00, AMC461852/\$40.00, AMC461853/\$40.00, AMC461854/\$40.00, AMC461855/\$40.00, AMC461856/\$40.00		- n/a -	280.00
3	7.00	LOCATABLE MINERALS / MINING CLAIMS-NEW, UNADJUD, ONE OR MORE AUTH NOS / NEW MINING CLAIMS MAINTENANCE FEE CASES: AMC461850/\$165.00, AMC461851/\$165.00, AMC461852/\$165.00, AMC461853/\$165.00, AMC461854/\$165.00, AMC461855/\$165.00, AMC461856/\$165.00		- n/a -	1155.00
TOTAL:					\$1,575.00

PAYMENT INFORMATION			
1	AMOUNT:	1575.00	POSTMARKED: N/A
	TYPE:	CHECK	RECEIVED: 11/23/2020
	CHECK NO:	1087	
	NAME:	LIAZUS INC	

ENTERED
 DEC 02 2020
 BY: *WU*

	242 LINDEN ST FORT COLLINS CO 80524-2424 US
--	--

REMARKS

This receipt was generated by the automated BLM Collections and Billing System and is a paper representation of a portion of the official electronic record contained therein.

OSDS 5 0 3 3 0

CORRESPONDENCE

TRANSFERS

MAINTENANCE FEES
WAIVERS
POL/NOI

MISCELLANEOUS

To whom it may concern,

Please accept the enclosed check to file the enclosed certifier of location for claims located in Mohave County, AZ.

Sincerely,

Patrick Sighle

242 Linden St

Fort Collins, CO 80524

720-258-6329

7 x unpatented lode claims to BLM

1 map

AMC461850

RECEIVED
BLM AZ STATE OFFICE
2020 NOV 23 A 9:09
PHOENIX, ARIZONA

**LOCATION NOTICES
AMENDMENTS
STATUS SHEET
GEO REPORT/MTP**

MINING CLAIM STATUS REPORT - Assessment Year 2020-2021

Data Entered: 12/2/2020 ML

MTP Checked By: ML
GEO Checked By: ML

LEAD SERIAL NUMBER: AMC 461850 thru AMC 461856

NUMBER OF CLAIMS & TYPE:
7 LODE
____ PLACER
____ ASSOCIATION PLACER
____ MILL SITE
____ TUNNEL SITE

CHARGES:
Processing Fee @ \$20 = \$ 140
Location Fee @ \$40 = \$ 280
Maintenance Fee @ \$165 = \$ 1155
Add'l Maint Fee for Assoc Placer = \$ _____
SUBTOTAL \$ 1575.
Other Fees \$ _____
Other Fees \$ _____
TOTAL \$ _____

TOTAL ACREAGE: _____ Per Claim
(Placer Only)

NUMBER OF LOCATORS: 1

DOCUMENTS RECEIVED VIA: Over-the-Counter [] Mail [X] TIMELY FILED: Yes [X] No []

LEGAL DESCRIPTION: T 17N R 16W SEC 4,5
T _____ R _____ SEC _____
T _____ R _____ SEC _____
T _____ R _____ SEC _____
T _____ R _____ SEC _____

BLM [] FOREST SERVICE [] SUBJ TO PL 359: Yes [] No []
WILDERNESS AREA [] _____

SPLIT ESTATE: N/A [] SX [] PX [] OTHER [] _____
SRHA [] Was proper Notice filed if located on SHRA Land? Yes [] No []

RECONVEYED MINERALS ON BLM LAND REQUIRE OPENING ORDER FROM 1944 TO 1993:
Open to Entry On _____ N/A []

COMMENTS/STATUS: VOID [] PARTIALLY VOID [] PVT MINERALS [] WITHDRAWN LANDS []
OTHER [] _____

[] Claimant acknowledges that portions of the following claim(s) site(s) may be void or voidable.

Printed Name of Claimant _____ Signature of Claimant _____

*****FINAL ADJUDICATION*****

DATE _____ INITIALS _____

AMC 461850

*Claim Map ANT Lode Claims - Part of
T 17 N, R 16 W, GSR Mer.
Mohave County, Arizona.*



AMC461850

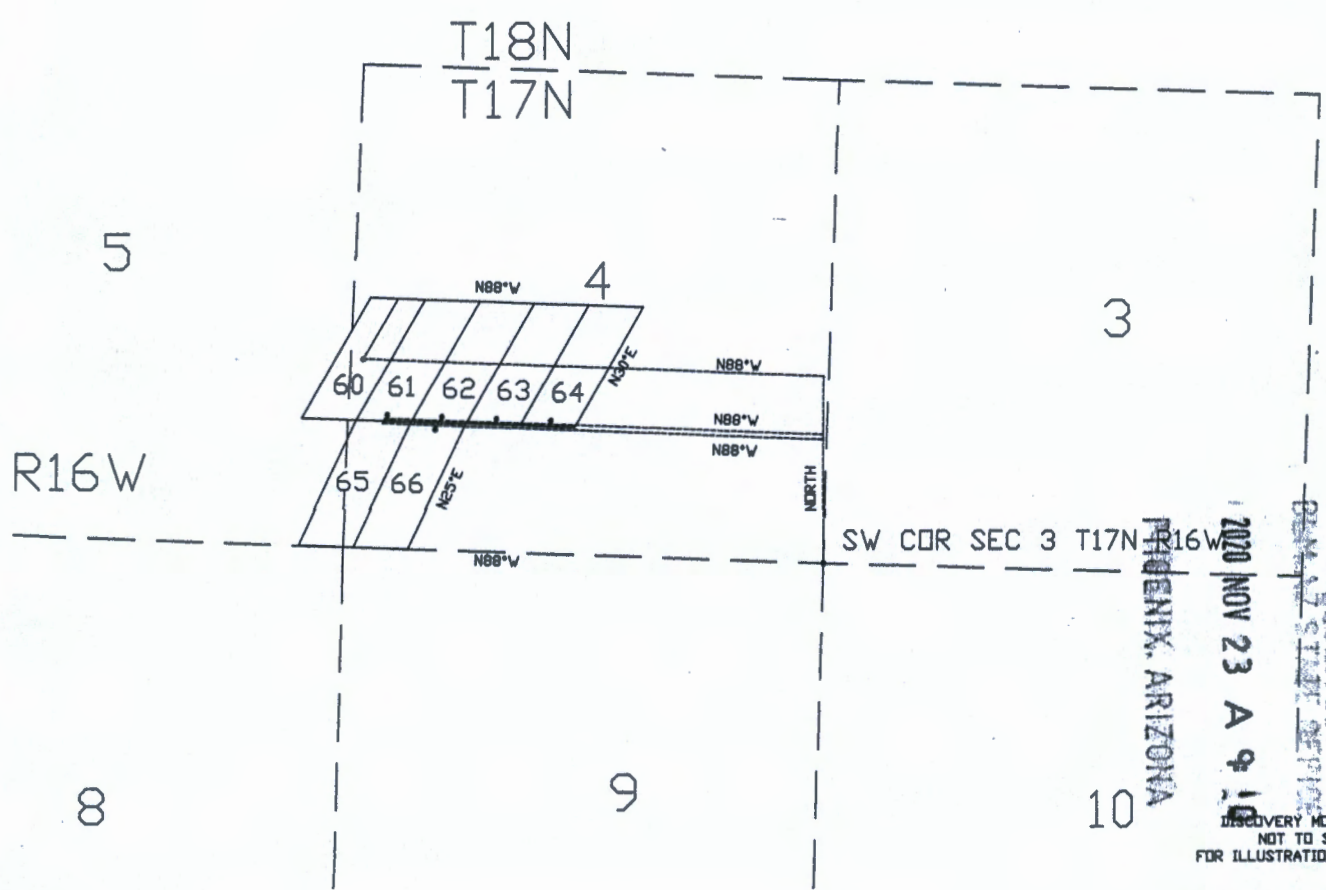

RECEIVED
DEPARTMENT OF STATE SERVICES
NOV 23 2020
PHOENIX, ARIZONA
DISCOVERY MONUMENTS
NOT TO SCALE
FOR ILLUSTRATION PURPOSES

TYPICAL CLAIM - NOT TO SCALE

DISCOVERY POST	NORTH	N88°W
CLAIM 60	2,030'	5,406'
CLAIM 61	1,400'	4,830'
CLAIM 62	1,400'	4,206'
CLAIM 63	1,400'	3,606'
CLAIM 64	1,400'	3,006'
CLAIM 65	1,345'	4,860'
CLAIM 66	1,345'	4,260'

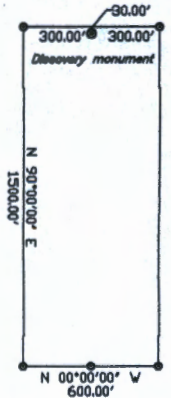

2"x2" post or a blazed tree 4" or greater

LOCATED SEPTEMBER 8, 2020

CLAIM MAP - ANT CLAIMS			
CORIZONA LLC			
T. 17 N., R. 16 W., GSR Mer.			
CORIZONA LLC	JOB NO. 001010	SECRET	
242 Linden Street	DATE 09-18-2020	1	
Fort Collins, CO 80524	CHECKED BY JJ	OF	
	DATE 09-23-2020	1	

Date and Time Run:
12/2/2020 11:12:31 AM

Page 1 of 1

DEPARTMENT OF THE INTERIOR
BUREAU OF LAND MANAGEMENT
Case Recordation

Geographic Report with Land

Disposition is equal to **AUTHORIZED , CANCELLED , EXPIRED , PENDING , REJECTED , RELINQUISHED ,
WITHDRAWN**

and Meridian Township Range Section is equal to 14 0170N 0160W 004

and Admin State is equal to AZ

**NO WARRANTY IS MADE BY BLM
FOR USE OF THE DATA FOR
PURPOSES NOT INTENDED BY BLM**

DEPARTMENT OF THE INTERIOR
BUREAU OF LAND MANAGEMENT
Case Recordation
Geographic Report with Land

Admin State: AZ
Geo State: AZ
Serial Number: AZA 025493

Total Case Acres: 40,402.000

Casetype	Case Disp	Mer	Twp	Rng	Sec	Sur Type	Sur Nr	Suf	Subdivision	Pending Action
231106	AUTHORIZED	14	0170N	0160W	004	ALIQU			SWNE,S2NW;	
						LOTS			1-5;	

Admin State: AZ
Geo State: AZ
Serial Number: AZA 038017

Total Case Acres: 1.700

Casetype	Case Disp	Mer	Twp	Rng	Sec	Sur Type	Sur Nr	Suf	Subdivision	Pending Action
380913	AUTHORIZED	14	0170N	0160W	004	ALIQU			S2;	

Admin State: AZ
Geo State: AZ
Serial Number: AZPHX 0034352

Total Case Acres: 342.470

Casetype	Case Disp	Mer	Twp	Rng	Sec	Sur Type	Sur Nr	Suf	Subdivision	Pending Action
285003	AUTHORIZED	14	0170N	0160W	004	LOTS			8;	

Date and Time Run:
12/2/2020 11:12:31 AM

Page 1 of 1

DEPARTMENT OF THE INTERIOR
BUREAU OF LAND MANAGEMENT
Case Recordation

Geographic Report with Land

Disposition is equal to **AUTHORIZED , CANCELLED , EXPIRED , PENDING , REJECTED , RELINQUISHED ,
WITHDRAWN**
and Meridian Township Range Section is equal to **14 0170N 0160W 005**
and Admin State is equal to **AZ**

NO WARRANTY IS MADE BY BLM
FOR USE OF THE DATA FOR
PURPOSES NOT INTENDED BY BLM

DEPARTMENT OF THE INTERIOR
BUREAU OF LAND MANAGEMENT
Case Recordation
Geographic Report with Land

Admin State: AZ
Geo State: AZ
Serial Number: AZA 023217AP

Total Case Acres: 135,762.680

Casetype	Case Disp	Mer	Twp	Rng	Sec	Sur Type	Sur Nr	Suf	Subdivision	Pending Action
220100	AUTHORIZED	14	0170N	0160W	005	ALIQ			S2N2,S2;	
						LOTS			1-4;	

Admin State: AZ
Geo State: AZ
Serial Number: AZA 025493

Total Case Acres: 40,402.000

Casetype	Case Disp	Mer	Twp	Rng	Sec	Sur Type	Sur Nr	Suf	Subdivision	Pending Action
231106	AUTHORIZED	14	0170N	0160W	005	ALIQ			S2N2,S2;	
						LOTS			1-4;	

